

Gex

Art.-Nr. 85000



- 1) Rokamat Gex (21GX0673)
- 2) 2014/30/EU, 2006/42/EG, 2012/19/EU, 2011/65/EU, 2001/95/EG, EG No. 1907/2006
- 3) EN 60745-1:2009/A11:2010, EN 60745-2-3:2011/A2:2013 + A11:2014 + A12:2014 + A13:2015, EN ISO 12100:2010-11
- 4) Kammerer GmbH, An der B 10, 75196 Remchingen

Remchingen, 15.04.2021

Beate Kammerer
Head of Technical Documentation

ROKAMAT

Kammerer GmbH
An der B 10
75196 Remchingen
Deutschland



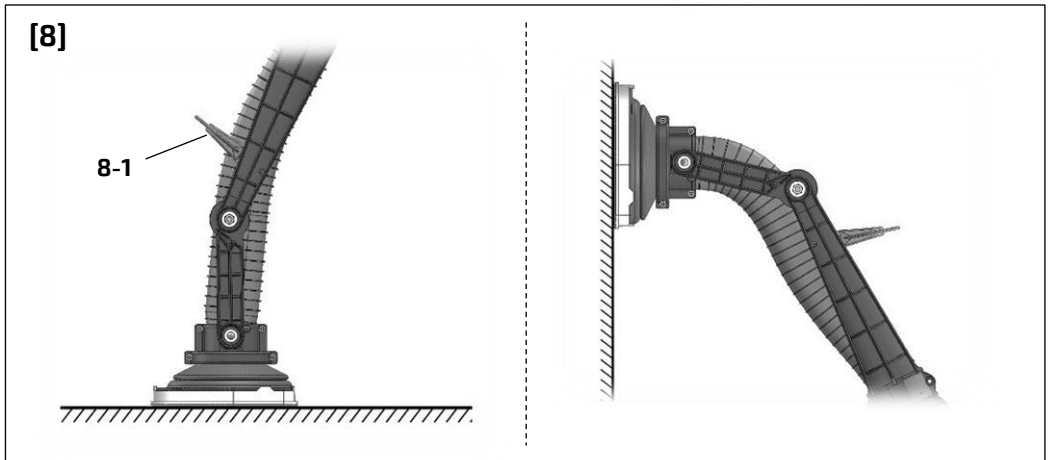
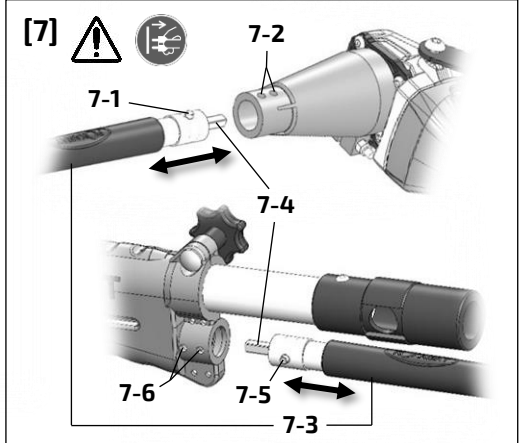
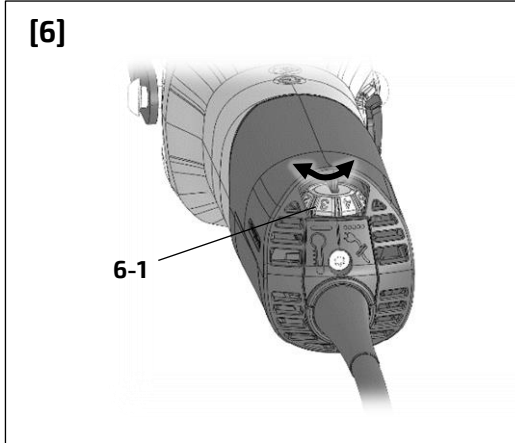
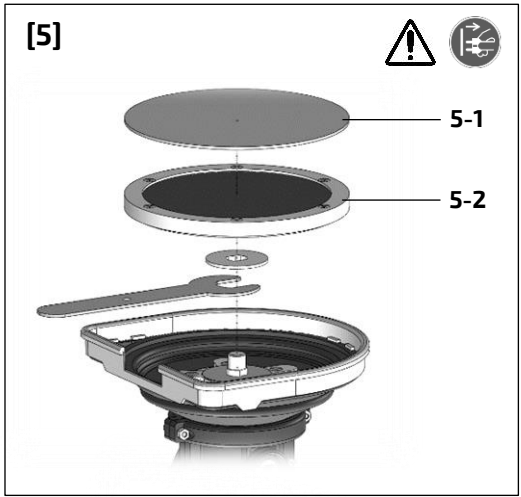
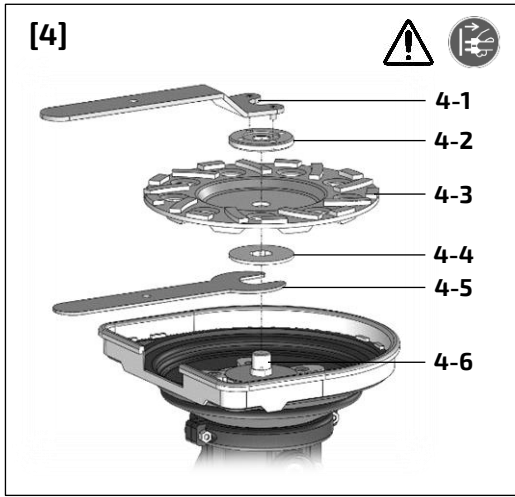
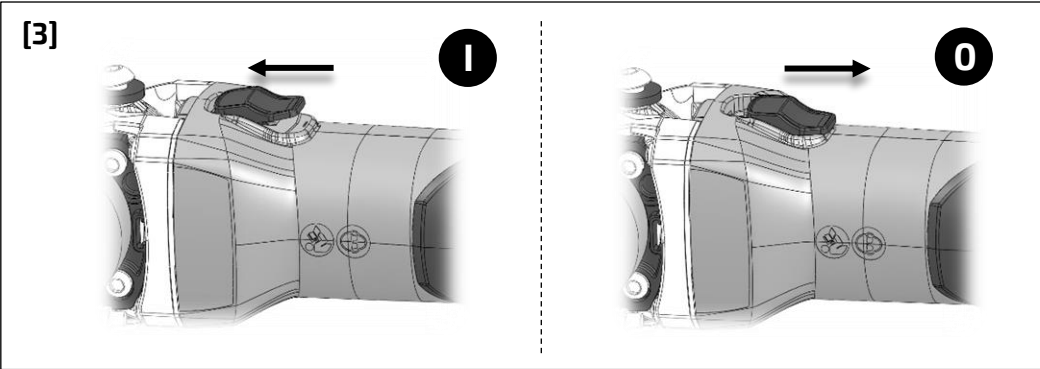
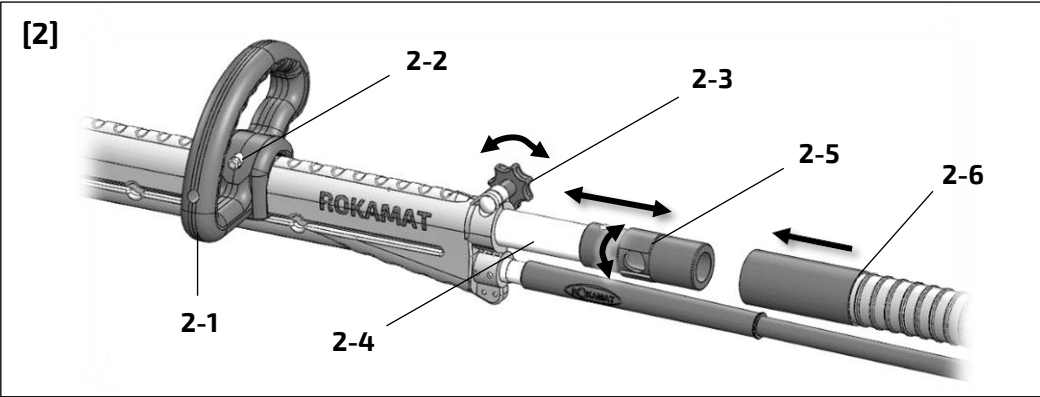
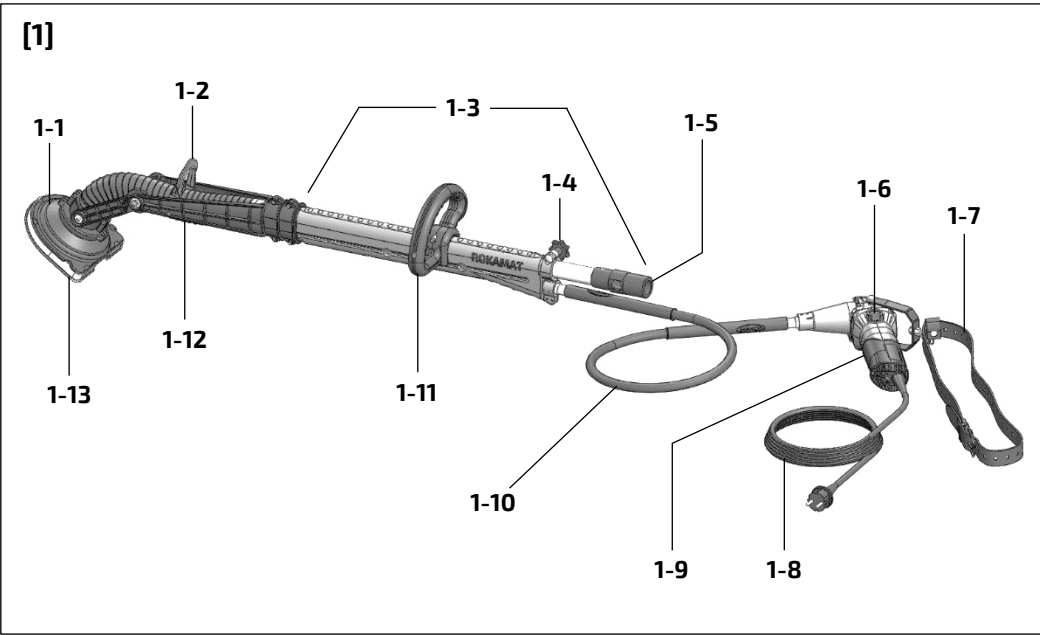

Contents

1. Symbols	3
2. Safety Instructions	3
3. Intended Use	4
4. Technical Specifications	4
5. Device Components	5
6. Commissioning	5
7. Instructions for Use	5
8. Working with the Power Tool	6
9. Maintenance and Care	6
10. Spare Parts and Accessories	6
11. Environmental Protection	6
12. Declaration of Conformity	6
13. Troubleshooting	7

1. Symbols



For your own protection and for the protection of your power tool, pay attention to all parts of the text that are marked with this symbol!



Risk of electric shock!



Read operating instructions and safety notices! *)



Wear protective goggles! *)



Wear ear protection!



Wear a dust mask!



Disconnect from the power supply!



Two-hand operation *)



Do not dispose of as domestic waste! *)



Important advice/information



Safety class I *)



~ Alternating current *)



Confirms the conformity of the power tool with the directives of the European Community. *)



Confirms the conformity of the power tool with UK legislation. *)

*) These symbols are (also) on the device.

2. Safety Instructions

For your safety



WARNING!

Read all safety warnings and instructions. Failure to follow all safety warnings and instructions may result in electric shock, fire and/or serious injury.



Do not use this power tool before you have thoroughly read and completely understood this Instruction Manual and the enclosed "General Safety Instructions".

Keep all safety instructions and information for future reference. Pass on your power tool only together with these documents.

Please also observe the relevant national industrial safety regulations.

Special Safety Instructions

Safety Warnings common for Grinding, Sanding and Polishing Operations:

- a) **This power tool is designed to be used as a sander (with sandpaper) and polisher. Read all safety warnings, instructions, illustrations and specifications provided with this power tool.** Failure to follow all instructions listed below may result in electric shock, fire and/or serious injury.
- b) **This power tool is not suitable for coarse sanding, sanding with a wire brush, polishing and abrasive cutting.** Operations for which the power tool was not designed may create a hazard and cause personal injury.
- c) **Do not use accessories which are not specifically designed and recommended by the tool manufacturer.** Just because the accessory can be attached to your power tool, it does not assure safe operation.
- d) **The rated speed of the accessory must be at least equal to the maximum speed marked on the power tool.** Accessories running faster than their rated speed can break and fly apart.

e) **The outside diameter and the thickness of your accessory must be within the capacity rating of your power tool.** Incorrectly sized accessories cannot be adequately guarded or controlled.

f) **Threaded mounting of accessories must match the grinder spindle thread. For accessories mounted by flanges, the arbor hole of the accessory must fit the locating diameter of the flange.** Accessories that do not match the mounting hardware of the power tool will run out of balance, vibrate excessively and may cause loss of control.

g) **Do not use a damaged accessory. Before each use inspect the accessory such as abrasive wheels for chips and cracks, backing pad for cracks, tear or excess wear, wire brush for loose or cracked wires. If power tool or accessory is dropped, inspect for damage or install an undamaged accessory. After inspecting and installing an accessory, position yourself and bystanders away from the plane of the rotating accessory and run the power tool at maximum no-load speed for one minute.** Damaged accessories will normally break apart during this test time.

h) **Wear personal protective equipment. Depending on application, use face shield, safety goggles or safety glasses. Where appropriate, wear dust mask, hearing protectors, gloves and workshop apron capable of stopping small abrasive or workpiece fragments.** The eye protection must be capable of stopping flying debris generated by various operations. The dust mask or respirator must be capable of filtering particles generated by your operation. Prolonged exposure to high intensity noise may cause hearing loss.

i) **Keep bystanders a safe distance away from work area. Anyone entering the work area must wear personal protective equipment.** Fragments of workpiece or of a broken accessory may fly away and cause injury beyond immediate area of operation.

j) **Hold the power tool by insulated gripping surfaces only, when performing an operation where the cutting accessory may contact hidden wiring or its own cord.** Cutting accessory contacting a "live" wire may make exposed metal parts of the power tool "live" and could give the operator an electric shock.

k) **Position the cord clear of the spinning accessory. If you lose control of the power tool, the cord may be cut or snagged and your hand or arm may be pulled into the spinning accessory.**

l) **Never lay the power tool down until the accessory has come to a complete stop.** The spinning accessory may grab the surface and pull the power tool out of your control.

m) **Do not run the power tool while carrying it at your side.** Accidental contact with the spinning accessory could snag your clothing, pulling the accessory into your body.

n) **Regularly clean the power tool's air vents.** The motor's fan will draw the dust inside the housing and excessive accumulation of powdered metal may cause electrical hazards.

o) **Do not operate the power tool near flammable materials.** Sparks could ignite these materials.

p) **Do not use accessories that require liquid coolants.** Using water or other liquid coolants may result in electrocution or shock.

Kickback and related warnings

Kickback is a sudden reaction to a pinched or snagged rotating wheel, backing pad, brush or any other accessory. Pinching or snagging causes rapid stalling of the rotating accessory which in turn causes the uncontrolled power tool to be forced in the direction opposite of the accessory's rotation at the point of the binding.

For example, if an abrasive wheel is snagged or pinched by the workpiece, the edge of the wheel that is entering into the pinch point can dig into the surface of the material causing the wheel to climb out or kick out. The wheel may either jump toward or away from the operator, depending on direction of the wheel's movement at the point of pinching. Abrasive wheels may also break under these conditions.

Kickback is the result of power tool misuse and/or incorrect operating procedures or conditions and can be avoided by taking proper precautions as given below.

- a) **Maintain a firm grip on the power tool and position your body and arm to allow you to resist kickback forces. Always use auxiliary handle, if provided, for maximum control over kickback or torque reaction during start-up.** The operator can control torque reactions or kickback forces, if proper precautions are taken.

- b) **Never place your hand near the rotating accessory.** Accessory may kickback over your hand.
- c) **Do not position your body in the area where power tool will move if kickback occurs.** Kickback will propel the tool in direction opposite to the wheel's movement at the point of snagging.
- d) **Use special care when working corners, sharp edges, etc. Avoid bouncing and snagging the accessory.** Corners, sharp edges or bouncing have a tendency to snag the rotating accessory and cause loss of control or kickback.
- e) **Do not attach a saw chain woodcarving blade or toothed saw blade.** Such blades create frequent kickback and loss of control over the power tool.

Safety Warnings Specific for Grinding Operations

Use only wheel types that are recommended for your power tool and the specific guard designed for the selected wheel. Wheels for which the power tool was not designed cannot be adequately guarded and are unsafe.

The grinding surface of the centre depressed wheels must be mounted below the plane of the guard lip. An improperly mounted wheel that projects through the plane of the guard lip cannot be adequately protected.

The guard must be securely attached to the power tool and positioned for maximum safety, so the least amount of wheel is exposed towards the operator. The guard helps to protect operator from broken wheel fragments and accidental contact with wheel and sparks which could ignite clothing.

Wheels must be used only for recommended applications.

Always use undamaged wheel flanges that are of correct size and shape for your selected wheel. Proper wheel flanges support the wheel thus reducing the possibility of wheel breakage. Flanges for cut-off wheels may be different from grinding wheel flanges.

Do not use worn down wheels from larger power tools. Wheel intended for larger power tool is not suitable for the higher speed of a smaller tool and may burst.

Safety warnings specific for grinding and sanding operations

Do not use excessively oversized sanding disc paper. Follow manufacturers recommendations, when selecting sanding paper. Larger sanding paper extending beyond the sanding pad presents a laceration hazard and may cause snagging, tearing of the disc or kickback.

Safety Warnings Specific for Polishing Operations



Do not allow any loose portion of the polishing bonnet or its attachment strings to spin freely. Tuck away or trim any loose attachment strings. Loose and spinning attachment strings can entangle your fingers or snag on the workpiece.

Additional safety instructions

Particles generated when working with this machine may contain substances that can cause cancer, allergic reactions, respiratory diseases, birth defects or other propagation defects. Some of these substances include: Lead (in paint containing lead), mineral dust (from bricks, concrete etc.), additives used for wood treatment (chromate, wood preservatives), some wood types (such as oak or beech dust), metals, asbestos.

The risk depends on for how long the user or nearby persons are exposed to the substance.

This dust must not be allowed to enter your body. Do the following to reduce exposure to these substances:

- Ensure good ventilation of the workplace.
- Wear appropriate protective equipment, such as respirators able to filter microscopically small particles.
-  To protect your health, wear a suitable protective mask.
-  Always wear protective goggles to protect against sanding hazards.
- Connect the electric power tool to a suitable extraction system.
- Sweeping or blowing stirs up dust.
- Vacuum or wash the protective clothing. Do not blow, beat or brush.

Collect the generated particles at the source, avoid deposits in the surrounding area.

Observe the relevant guidelines for your material, staff, application and place of application (e.g. occupational health and safety regulations, disposal).

If potentially explosive or self-igniting dust is produced during sanding, the machining instructions issued by the material manufacturer must always be followed.

Attention: Risk of fire! Avoid overheating the grinding material and the sander. Always empty the dust container before taking a break. Swarf in the filter bag or filter of the extraction system may self-ignite in unfavorable conditions such as flying sparks when grinding metals. Particular danger exists if the swarf is mixed with paint, polyurethane residue or other chemical materials and the grinding material is hot after long periods of work.

Damaged, eccentric or vibrating tools must not be used.

There must be no unprotected persons in the ejection direction of the tool and the immediate vicinity.

Always use an antistatic suction hose with the power tool. A slight electric shock may cause you to panic briefly and become distracted, which may result in an accident.

When the safety clutch responds, switch off the machine immediately!

Do not overload the motor for a long period. Engine noise should be regular (not wave-like). Unsteady engine performance can be perceived acoustically.

Take a break when the machine is heated up strongly and let it cool down again. To that let the motor idle at top speed for some time.

Don't bend the flexible drive shaft!

Start working with the lowest speed in order to get a feel for the machine.

Don't put the running motor on the ground! Dirt may get sucked in and cause damage.

Always use original ROKAMAT abrasives. Foreign abrasives are not suitable for the speed of the sander and may break.

Pull the plug out of the socket before making any adjustments, converting or servicing the machine.

Ensure sufficient cable clearance. Use only extension cables permitted for outdoor use.

Keep the carry case out of reach of children. Children may suffocate or be strangled when playing with the carry case.

Emission levels

NOTE! Values for the A-weighted sound pressure level and for the total vibration values can be found in the "Technical specifications" table at page 9.

The vibration emission level given in this information sheet has been measured in accordance with a standardized test and may be used to compare one tool with another. It may be used for a preliminary assessment of exposure.

CAUTION! The indicated measurements refer to new power tools. Daily use causes the noise and vibration values to change.

The declared vibration emission level represents the main applications of the tool. However, if the tool is used for different applications, with different accessories or poorly maintained, the vibration emission may differ. This may significantly increase the exposure level over the total working period. However, if the tool is used for different applications, with different accessories or poorly maintained, the vibration emission may differ. This may significantly decrease the exposure level over the total working period.

 **CAUTION!** The noise produced during work may damage your hearing. Wear ear protection!

3. Intended Use

The hand-guided long-neck grinder Gex is intended for the grinding and polishing of ceilings, walls and floors, indoors and outdoors. It is suitable for concrete and stone grinding, for removing concrete burrs, coatings, loose render as well as paint and adhesive residue, for levelling, roughening of screed and evening out butt joints. It may only be used for dry grinding. For grinding work, the unit may only be operated in combination with a suitable vacuum cleaner. The Gex is only intended for use with ROKAMAT metal and fibre discs.

Only sufficiently qualified and trained personnel is allowed to work with the grinder.

The intended use includes the observance of the operating instructions, in particular the safety instructions and the observance of generally recognized accident prevention regulations.

4. Technical Specifications

Grinder and polisher Gex Item No. 85000	
Rated voltage	230 V AC
Frequency	50 Hz
Power	1500 W
No-load speed	2580-9140 min ⁻¹

Maximum tool diameter	150 mm
Driver disc	M12x1,5 / 10 mm
Tool holder weight	2,9 kg
Total weight	6,8 kg
Max. tool thickness	4,0 mm
Dimension compact (LxHxW)	114x20x42 cm
Cable length	5,0 m
Safety class	I /
A-weighted sound pressure level (see cap. 2 "Emission levels"):	
Sound pressure level L_{pA}	90 dB(A)
Sound power level L_{WA}	101 dB(A)
Uncertainty K_{pA} , K_{WA}	3,0 dB
Total vibration value (see cap. 2 "Emission levels"):	
Emission value a_{rh} (Sanding operations)	< 2,5 m/s^2
Emission value a_{rh} (Concrete)	4,2 m/s^2
Uncertainty K	1,5 m/s^2

5. Device Components

The specified illustrations can be found in fig. [1] on page 2 of the operating instructions.

- 1-1 Grinding head
- 1-2 Lever
- 1-3 Handle (Gripping surface)
- 1-4 Clamping screw
- 1-5 Intake socket
- 1-6 Slide switch
- 1-7 Belt
- 1-8 Mains cable
- 1-9 Motor (with gripping surface)
- 1-10 Flexible drive shaft
- 1-11 Handle
- 1-12 Fork
- 1-13 Slide ring

6. Commissioning

	WARNING!
Unauthorised voltage or frequency! Risk of accident! The mains voltage and the frequency of the power source must correspond with the specifications on the machine's name plate.	

	CAUTION!
Before switching on the power tool: Unpack power tool and accessories and check that no parts are missing or damaged.	

Connecting the dust extraction system [2]

Push the suction hose [2-6] onto the intake socket [1-5]. Check for correct fit! If necessary, use a suitable adapter. See also chapter 7.

Motor mounting

The motor [1-9] is not allowed to be placed on the floor during operation, but must be hooked in the carabiner of the provided belt [1-7] (resp. shoulder belt).

Switching the electric power tool on and off [3]

Switching on: Push the sliding switch [1-6] forward. For continuous activation, now tilt downwards until it engages.

Switching off: Press the rear end of the slide switch [1-6] and release it.

7. Instructions for Use

	WARNING!
Risk of injury, electric shock! Always pull the mains plug out of the socket before performing any type of work on the machine!	

Attaching, changing or removing the diamond/ PCD/ hard metal rasping disc [4]

- Put the support flange [4-4] on the grinding spindle [4-6] so that the collar (square) points downwards.
- Place the grinding disc [4-3] on the grinding spindle.
- Put the clamping flange [4-2] on the grinding spindle with the undercut facing upwards. Fix the grinding spindle to the support flange collar using the wrench [4-5], then securely tighten the clamping flange clockwise using the face wrench [4-1].
- Removing in reverse order.

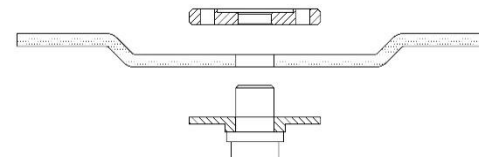

Attaching, changing or removing the supporting plate [5]

- Remove the clamping flange and grinding disc (see above).
- Fix the grinding spindle to the support flange collar using the wrench, then place the supporting plate [5-2] centrally on the grinding spindle and tighten by hand by turning clockwise.
- Removing in reverse order.

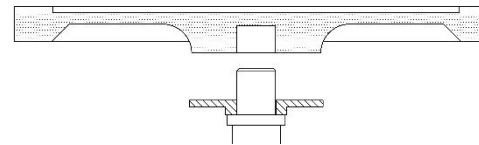

Attaching or changing the abrasive with velcro [5]

- Remove the (worn) abrasive [5-1] from the supporting plate.
- Place the abrasive in the center of the supporting plates and press on.
- Conduct a test run to check that the abrasives are attached in the center.

Adjusting the speed [6]

Set the recommended speed at the thumbwheel [6-1]. (small number = low speed; large number = high speed).

	ADVICE!
When working with PCD grinding disc, ABRA-FILM/ polishing/ emery discs: set low speed (level 1-3).	

Suction flow regulation [2]

Turn the sleeve [2-5] to regulate the suction flow. Completely open = min. suction flow
Completely closed = max. suction flow.

Handle [2]

- Push in the bolts [2-1] on the bow handle [2-2].
- Move bow handle to desired position.
- Loosen bolts and allow to engage.

Telescopic tube [2]

- Open the clamping screw [2-3].
- Move the telescopic tube [2-4] to the desired position.
- Lock the clamping screw.

Angle adjustment [8]

- Pull lever [8-1].
 - Set the desired angle.
 - Release lever and allow bolt to engage.
- The angle adjustment allows for ergonomic work. It should also be ensured that the abrasive always lies *parallel* on the surface to be worked on.

Work on ceiling and floor: It should also be ensured that the abrasive always lies *parallel* on the surface to be worked on.

Work on wall: Angle the fork. Hold the grinder almost perpendicular to the work surface.

	ADVICE!
These recommendations may vary slightly depending on body size.	



Grinding head/Grinding close to edges

The slide ring [1-13] retains the dust until it is extracted by the dust extractor. As the slide ring projects above the surface of the sanding plate, it is the slide ring which comes into contact with the work surface first. As a result, the grinding head is brought parallel to the work surface before the grinding tool comes into contact with the work surface. This avoids a sickle-shaped depression caused by the edge of the sanding or diamond grinding disc.

If the brush ring is damaged or shows excessive wear, it should be replaced (see chapter 9).

	WARNING!
Risk of injury! Never work without a slide ring! Do not turn the slide ring by hand while the machine is in operation!	

Dust extraction

  WARNING!
Health hazard posed by dust! Always work with an extractor. Comply with national regulations. When using the long-neck grinder, connect a Class M dust extractor. Wear a dust mask!

The dust extraction system offered on our website is adapted to the quantity of dust generated and permanently ensure the necessary suction power.

 ADVICE!
Always use an antistatic suction hose! This helps reduce the electrostatic charge.

8. Working with the Power Tool



1. Attach grinding tool.
2. Connect dust extraction system.
3. Attach motor to (shoulder) belt.
4. Insert mains plug.
5. Set required speed.
6. Switch on dust extraction system.
7. Hold the long-neck grinder with both hands at the gripping surfaces. This provides the best possible combination of range and leverage for the application.
8. Switch on the device.
9. Press the long-neck grinder gently against the work surface (the pressure should be just enough to ensure that the grinding head is flush with the work surface).
10. Increase the pressure to bring the sanding sheet into contact with the work surface. In doing so, swing the long neck grinder in overlapping movements to smooth the surface to the required fineness.

After finishing work

Once you have finished the grinding work, set the power tool down.

 CAUTION!
Do not set the power tool down with the grinding head facing downwards – always lay it on the floor so that it is on its side! Otherwise the supporting plate could be deformed.

9. Maintenance and Care

   WARNING!
Risk of injury, electric shock! Always disconnect the mains plug from the socket before performing maintenance work on the machine!

- Repairs may be carried out by an authorized customer service center only.
- Repairs to electrical tools must be carried out by qualified electricians only!

Check the plug and the cable regularly and should either become damaged, in order to avoid a hazard, have them replaced by an authorized customer service center.

During the warranty period do not loosen the screws on the housing. Non-compliance will deem the guarantee obligations of the manufacturer null and void.

Remove dust from the motor regularly

It is possible that particles deposit inside the power tool during operation. This impairs the cooling of the power tool. Conductive build-up can impair the protective insulation of the power tool and cause electrical hazards.

The power tool should be cleaned regularly, often and thoroughly through all front and rear air vents using a vacuum cleaner or by blowing in dry air. Prior to this operation, separate the power tool from the power source and wear protective glasses and dust mask.

Replacement of the flexible drive shaft [7]

 CAUTION!
The two boreholes for the push button at the drive shaft serve as length adjustment between shaft core and protective hose. The shaft core should be freely movable in length and must not get compressed!

Disassembling: On the motor side, press in the press button [7-1] in the borehole [7-2] with a tool (e.g. screwdriver) and pull out the protective hose [7-3]. Now the shaft core [7-4] can be replaced. To replace the protective hose [7-3], it must also be loosened on the side of the tool holder. To do this, press in the press button [7-5] in the borehole [7-6]

with a tool (e.g. screwdriver) and pull out the protective hose [7-3].

Mounting: In reverse order. Make sure that the shaft core [7-4] is threaded into the square in each case.

Exchanging the slide ring

First, the grinding tool must be removed (see chap. 7). The slide ring is engaged in the grinding head at several points. In order to remove the slide ring, it must be loosened at these points by levering. Engage the new slide ring on the corresponding one. Then, the correct position and the fixing must be checked.

 ADVICE!
Check all wearing parts once a month.

Handling and storage

Operation

Temperature range: +5° C to +50° C
Humidity: ≤ 85 %, non-condensing
Climate: dry

Transport and storage

Temperature range: -5° C to +55° C
Humidity: 0 % to 70 %
Climate: dry, roofed, dew protected
Keep out of reach of children.

10. Spare Parts and Accessories

Other accessories, in particular insertion tools, can be found in the manufacturer's catalogues. Exploded drawings and spare-part lists can be found on our homepage: www.rokamat.com.

Use only original ROKAMAT spare parts and work tools!

11. Environmental Protection

The generated grinding dust may contain harmful substances. Dispose appropriately.

Observe national regulations on environmentally compatible disposal and on the recycling of disused machines, packaging and accessories.

 **For Great Britain and EU countries:** Never dispose of power tools in your household waste! In accordance with WEEE relating for electrical and electronic waste and

implementation of national law, used electrical tools must be collected separately and disposed of in an environmentally friendly manner at recycling centers. Separate the motor from the rest of the machine before disposal. Make used tools unusable by removing the mains cable.

 ADVICE!
Please ask your dealer about disposal options!

12. Declaration of Conformity

It is expressly declared that the grinder and polisher listed on the first page under 1) from the serial number indicated onwards complies with all relevant provisions of the directives or regulations listed in 2) and that the harmonized standards listed in 3) have been applied. The technical documentation is available from the authorized documentation agent named in 4).

13. Troubleshooting

Problem	Possible causes	Remedy
Motor runs, but the supporting plate does not rotate.	Shaft core broken.	Exchange shaft core.
The electronic signal display [6-1] lights up and the load speed decreases.	There is too much load on the machine.	Run the machine in idling until the electronics signal indicator switches off.
The machine does not start. The electronic signal display [6-1] flashes.	The restart protection is active. If the mains plug is inserted with the machine switched on, or if the power supply is restored following an interruption, the machine does not start up.	Switch the machine off and on again.
Motor power fluctuates.	Carbon brushes worn.	Replace carbon brushes.
Gex not working.	Cable break.	Replace mains plug.
	Interruption to power supply.	Switch the power tool off and on again.
Gex does not run smoothly over the surface.	Hard material or hard grounds.	Adjust speed. Reduce suction pressure: open suction flow regulator (if available).
	Deformed grinding plate.	Use a new grinding plate.
Excessive material removed from workpiece.	Speed too high.	Reduce the speed.
	Grit on abrasives too coarse.	Select a finer grit.
Surface quality not perfect.	Incorrect or worn tool discs.	Select correct tool discs and check for good condition.
	Power tool running when set down on the surface (groove formation).	Place the power tool in position and then switch it on. Always use a slide ring when working on the surface.
Grinding marks on the surface.	Grinding plate is placed down on the surface at an angle.	Place the grinding plate down so that it is level.
Electrostatic charge.	Machine not grounded.	Use antistatic suction hose with suitable vacuum cleaner.
Extraction power is insufficient.	Filter element on the dust extraction system is blocked/clogged.	Clean the filter element regularly.
	Disposal bag inserted incorrectly.	Installing the disposal bag correctly.
	The suction power on the dust extraction system is too low.	Adjust the suction power to a higher setting.
	Speed too high.	Reduce speed.
	Suction hose blocked or kinked.	Remove blockage and straighten hose.
	Disposal bag full.	Dispose of the bag.
Slide ring damaged.	Replace slide ring.	

If problems other than those listed occur, please contact your ROKAMAT service workshop or your local specialist.