

Hedgehog W

Art.-Nr. 69600

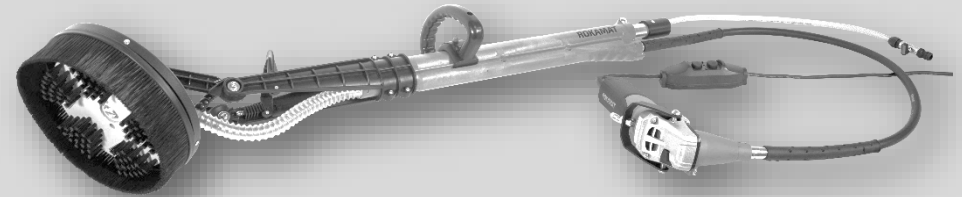

- 1) Rokamat Hedgehog W (22IGC0093)
- 2) 2014/30/EU, 2006/42/EG, 2012/19/EU, 2011/65/EU, 2001/95/EG, EG No. 1907/2006
- 3) EN 62841-1:2015/AC:2015; EN 62841-2-4:2014/AC:2015; EN ISO 12100:2010-11
- 4) Kammerer GmbH | An der B 10 | D-75196 Remchingen

Remchingen, 20.01.2022



Beate Kammerer
Head of Technical Documentation

ROKAMAT

Kammerer GmbH
An der B 10
75196 Remchingen
Deutschland



[1]

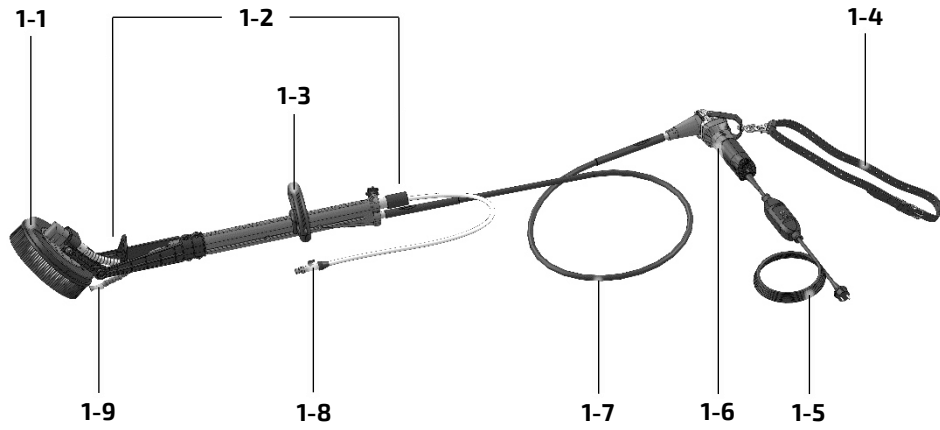

[2]

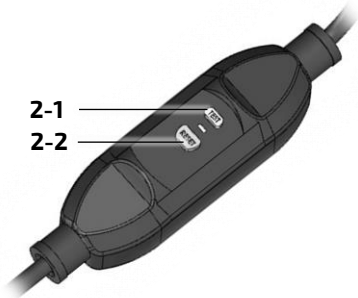

[3]

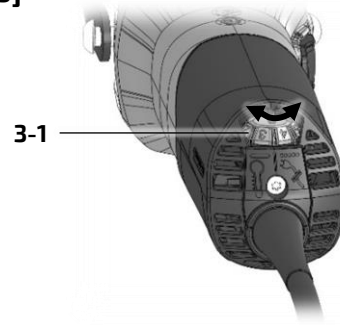

[4]

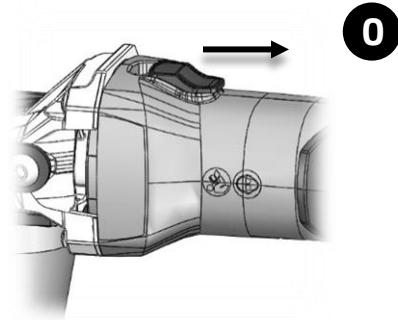
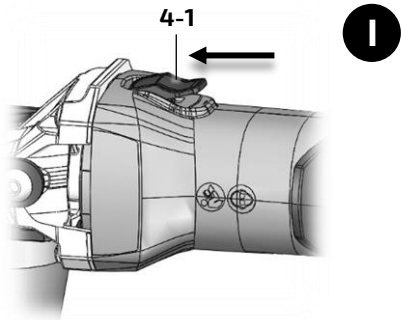

[5]

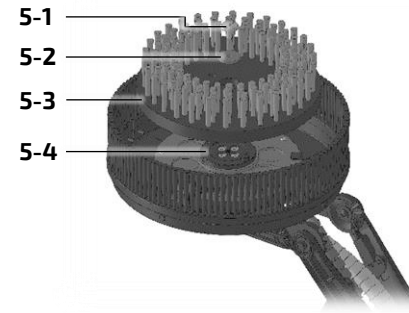

[6]

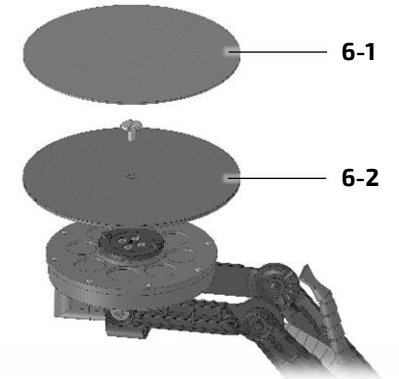

[7]

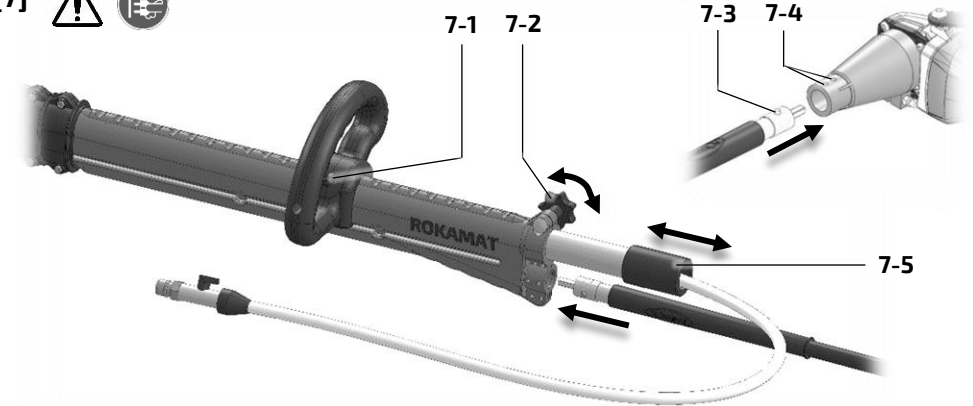

[8]

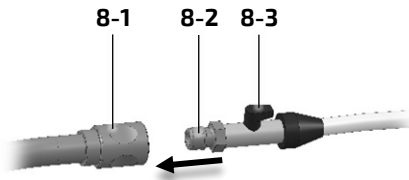

[9]

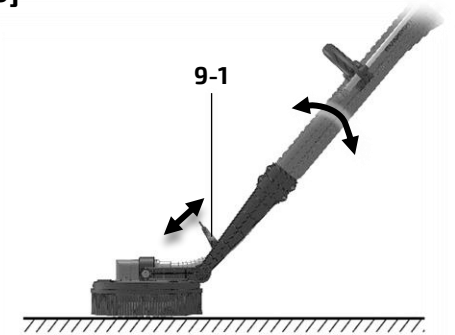

Contents

1. Symbols	3
2. Safety Instructions	3
3. Intended Use	4
4. Technical Specifications	4
5. Device Components	4
6. Commissioning	4
7. Instructions for Use	4
8. Working with the Power Tool	5
9. Maintenance and Care	5
10. Spare Parts and Accessories	5
11. Environmental Protection	5
12. Declaration of Conformity	6
13. Troubleshooting	6

1. Symbols



For your own protection and for the protection of your power tool, pay attention to all parts of the text that are marked with this symbol!



Risk of electric shock!



Read operating instructions and safety notices! *)



Wear protective goggles! *)



Wear ear protection!



Disconnect from the power supply!



Two-hand operation. *)



Do not dispose of as domestic waste! *)



Important advice/information



Safety class II *)



~ Alternating current *)



Confirms the conformity of the power tool with the directives of the European Community. *)



Confirms the conformity of the power tool with UK legislation. *)

*) These symbols are (also) on the device.

2. Safety Instructions

For your safety



WARNING!

Read all safety warnings and instructions. Failure to follow all safety warnings and instructions may result in electric shock, fire and/or serious injury.



Do not use this power tool before you have thoroughly read and completely understood this Instruction Manual and the enclosed "General Safety Instructions".

Keep all safety instructions and information for future reference. Pass on your power tool only together with these documents.

Please also observe the relevant national industrial safety regulations.

Special Safety Instructions

Safety Warnings common for Grinding, Sanding and Polishing Operations:

- a] **This power tool is designed to be used as a sander (with sandpaper) and polisher. Read all safety warnings, instructions, illustrations and specifications provided with this power tool.** Failure to follow all instructions listed below may result in electric shock, fire and/or serious injury.
- b] **This power tool is not suitable for coarse sanding, sanding with a wire brush, polishing and abrasive cutting.** Operations for which the power tool was not designed may create a hazard and cause personal injury.
- c] **Do not use accessories which are not specifically designed and recommended by the tool manufacturer.** Just because the accessory can be attached to your power tool, it does not assure safe operation.
- d] **The rated speed of the accessory must be at least equal to the maximum speed marked on the power tool.** Accessories running faster than their rated speed can break and fly apart.
- e] **The outside diameter and the thickness of your accessory must be within the capacity rating of your power tool.** Incorrectly sized

accessories cannot be adequately guarded or controlled.

- f] **Threaded mounting of accessories must match the grinder spindle thread. For accessories mounted by flanges, the arbor hole of the accessory must fit the locating diameter of the flange.** Accessories that do not match the mounting hardware of the power tool will run out of balance, vibrate excessively and may cause loss of control.
- g] **Do not use a damaged accessory. Before each use inspect the accessory such as abrasive wheels for chips and cracks, backing pad for cracks, tear or excess wear, wire brush for loose or cracked wires. If power tool or accessory is dropped, inspect for damage or install an undamaged accessory. After inspecting and installing an accessory, position yourself and bystanders away from the plane of the rotating accessory and run the power tool at maximum no-load speed for one minute.** Damaged accessories will normally break apart during this test time.
- h] **Wear personal protective equipment. Depending on application, use face shield, safety goggles or safety glasses. Where appropriate, wear dust mask, hearing protectors, gloves and workshop apron capable of stopping small abrasive or workpiece fragments.** The eye protection must be capable of stopping flying debris generated by various operations. The dust mask or respirator must be capable of filtering particles generated by your operation. Prolonged exposure to high intensity noise may cause hearing loss.
- i] **Keep bystanders a safe distance away from work area. Anyone entering the work area must wear personal protective equipment.** Fragments of workpiece or of a broken accessory may fly away and cause injury beyond immediate area of operation.
- j] **Hold the power tool by insulated gripping surfaces only, when performing an operation where the cutting accessory may contact hidden wiring or its own cord.** Cutting accessory contacting a "live" wire may make exposed metal parts of the power tool "live" and could give the operator an electric shock.
- k] **Position the cord clear of the spinning accessory.** If you lose control of the power tool, the cord may be cut or snagged and your hand or arm may be pulled into the spinning accessory.

- l] **Never lay the power tool down until the accessory has come to a complete stop.** The spinning accessory may grab the surface and pull the power tool out of your control.
- m] **Do not run the power tool while carrying it at your side.** Accidental contact with the spinning accessory could snag your clothing, pulling the accessory into your body.
- n] **Regularly clean the power tool's air vents.** The motor's fan will draw the dust inside the housing and excessive accumulation of powdered metal may cause electrical hazards.
- o] **Do not operate the power tool near flammable materials.** Sparks could ignite these materials.
- p] **Do not use accessories that require liquid coolants.** Using water or other liquid coolants may result in electrocution or shock.

Kickback and related warnings

Kickback is a sudden reaction to a pinched or snagged rotating wheel, backing pad, brush or any other accessory. Pinching or snagging causes rapid stalling of the rotating accessory which in turn causes the uncontrolled power tool to be forced in the direction opposite of the accessory's rotation at the point of the binding.

For example, if an abrasive wheel is snagged or pinched by the workpiece, the edge of the wheel that is entering into the pinch point can dig into the surface of the material causing the wheel to climb out or kick out. The wheel may either jump toward or away from the operator, depending on direction of the wheel's movement at the point of pinching. Abrasive wheels may also break under these conditions.

Kickback is the result of power tool misuse and/or incorrect operating procedures or conditions and can be avoided by taking proper precautions as given below.

- a] **Maintain a firm grip on the power tool and position your body and arm to allow you to resist kickback forces. Always use auxiliary handle, if provided, for maximum control over kickback or torque reaction during start-up.** The operator can control torque reactions or kickback forces, if proper precautions are taken.
- b] **Never place your hand near the rotating accessory.** Accessory may kickback over your hand.

- c] **Do not position your body in the area where power tool will move if kickback occurs.** Kickback will propel the tool in direction opposite to the wheel's movement at the point of snagging.
- d] **Use special care when working corners, sharp edges, etc. Avoid bouncing and snagging the accessory.** Corners, sharp edges or bouncing have a tendency to snag the rotating accessory and cause loss of control or kickback.
- e] **Do not attach a saw chain woodcarving blade or toothed saw blade.** Such blades create frequent kickback and loss of control over the power tool.

Additional safety instructions

Never immerse the machine in water or spray it with water for cleaning, not even the tool holder!

Keep liquids away from the power tool and persons in the work area.

Don't bend the flexible drive shaft!

Bei Ansprechen der Sicherheitskupplung die Maschine sofort ausschalten!

When the safety clutch responds, switch off the machine immediately!

Do not overload the motor for a long period. Engine noise should be regular (not wave-like). Unsteady engine performance can be perceived acoustically.

Take a break when the machine is heated up strongly and let it cool down again. To that let the motor idle at top speed for some time.

Ensure sufficient cable clearance. Use only extension cables permitted for outdoor use.

Emission levels

NOTE! Values for the A-weighted sound pressure level and for the total vibration values can be found in the "Technical specifications" table at page 9.

The vibration emission level given in this information sheet has been measured in accordance with a standardized test and may be used to compare one tool with another. It may be used for a preliminary assessment of exposure.

CAUTION! The indicated measurements refer to new power tools. Daily use causes the noise and vibration values to change.

The declared vibration emission level represents the main applications of the tool. However, if the tool is used for different applications, with different accessories or poorly maintained, the vibration emission may differ. This may significantly

increase the exposure level over the total working period. However, if the tool is used for different applications, with different accessories or poorly maintained, the vibration emission may differ. This may significantly decrease the exposure level over the total working period.

 **CAUTION! The noise produced during work may damage your hearing.**
Wear ear protection!

Handling and storage

Operation

Temperature range: +5° C to +50° C

Humidity: ≤ 85 %, non-condensing

Climate: dry

Transport and storage

Temperature range: -5° C to +55° C

Humidity: 0 % to 70 %

Climate: dry, roofed, dew protected

Transport and store the power tool only in the carrying case. Before transport or storage, remove water completely from the machine. Keep the carry case out of reach of children. Children may suffocate or be strangled when playing with the carry case.

3. Intended Use

The hand-held electric tool Rokamat **Hedgehog W** is intended for removing of concrete residues on formwork elements and for cleaning ceilings, walls and floors in exterior and interior areas

With the **Hedgehog W**, machining can be performed with water supply via the integrated water injection. **The Hedgehog W may only be operated in conjunction with a portable residual current device (PRCD).**

The PFM W is intended for use with original ROKAMAT tools and accessories only.

Only sufficiently qualified and trained personnel is allowed to work with the tool. The intended use includes the observance of the operating instructions, in particular the safety instructions and the observance of generally recognized accident prevention regulations.

In case of misuse, the manufacturer is not liable and warranty claims may be void.

4. Technical Specifications



Formwork cleaning machine Hedgehog W Item No. 69600	
Rated voltage	230 V AC
Frequency	50 Hz
Power	1000 W
No-load speed	480-1670 min ⁻¹
Maximum tool diameter	200 mm
Driver disc	Befestigungsschraube M6
Tool holder weight	3,7 kg
Total weight	7,0 kg
Dimension compact (LxHxW)	1135x200x420 mm
Cable length	5,0 m
Residual current detection	PRCD (10 mA)
Safety class	II / 
A-weighted sound pressure level (see cap. 2 "Emission levels"):	
Sound pressure level L _{pA}	87 dB(A)
Sound power level L _{WA}	95 dB(A)
Uncertainty K _{pA} , K _{WA}	3,0 dB
Total vibration value (see cap. 2 "Emission levels"):	
Emmission value a _h	< 2,5 m/s ²
Uncertainty K	1,5 m/s ²

5. Device Components

The specified illustrations can be found in fig. [1] on page 2 of the operating instructions.

- 1-1 Splash guard
- 1-2 Gripping surface
- 1-3 Handle
- 1-4 Belt
- 1-5 Mains cable with PRCD
- 1-6 Motor (with gripping surface)
- 1-7 Flexible drive shaft
- 1-8 Flow control valve
- 1-9 Water nozzle with hose

6. Commissioning

  **WARNING!**

Unauthorized voltage or frequency! Risk of accident!
The mains voltage and the frequency of the power source must correspond with the specifications on the machine's name plate.
Before each start of work, check the proper operation of the PRCD by pressing the TEST button.

 **CAUTION!**

Before switching on the power tool: Unpack power tool and accessories and check that no parts are missing or damaged.

Motor mounting



The motor [1-6] is not allowed to be placed on the floor during operation, but must be hooked in the carabiner of the provided belt [1-4] (resp. shoulder belt).

Switching the electric power tool on and off [2+4]

Switching on: Switch on the PRCD (TEST) [2-1] and push the sliding switch [4-1] forward. For continuous activation, now tilt downwards until it engages.

Switching off: Switch off the PRCD (TEST) [2-2]. Press the rear end of the slide switch [4-1] and release it.

7. Instructions for Use

   **WARNING!**

Risk of injury, electric shock!
Always pull the mains plug out of the socket before performing any type of work on the machine!

Attaching, changing or removing the cleaning brushes [5]

- Centre the cleaning brush [5-3] directly on the driver disc [5-4]. Ensure that both pins on the driver disc mate with the drill holes in the cleaning brush.
- Then turn the clamping screw [5-1] clockwise together with the rubber washer [5-2] to tighten them.

- Conduct a test run to check that the cleaning brush is attached in the center.
- Removing in reverse order.

Attaching, changing or removing the cleaning pad [6]

- Centre the supporting plate [6-2] directly on the driver disc [5-4]. Ensure that both pins on the driver disc mate with the drill holes in the supporting plate.
- Then turn the clamping screw [5-1] clockwise *without the rubber washer [5-2]* to tighten them.
- Place the cleaning pad [6-1] in the center of the supporting plate [6-2] and press on.
- Conduct a test run to check that the cleaning pad is [6-1] attached in the center.
- Removing in reverse order.

Adjusting the speed [3]

Set the recommended speed at the thumbwheel [3-1]. (small number = low speed; large number = high speed).

Water injection [8]



CAUTION!

Risk of damage to the device! Risk of injury!

Use only clean water, otherwise the nozzle [9-1] could be blocked.
Water injection may be used only for moistening suitable surface!
A maximum of 5 bar is permissible for the fluid system.

- Connect the water hose [8-1] (not included in the scope of delivery) to the hose connection [8-2]. Activate water supply.
- Press the handle [8-3] of the lever valve [1-8] to activate the water outlet.
- Release the lever valve again to stop the water outlet.

Depending on the position of the lever [8-3], the water outlet can be regulated. Adjust the water nozzle [1-9] by bending the hose.



CAUTION!

The hose connection [8-2] is suitable for conventional hose connectors.

Angle adjustment [9]

- Pull lever [9-1].

- Set the desired angle.
- Release lever [9-1] and allow bolt to engage.

The angle adjustment allows for ergonomic work. It should also be ensured that the abrasive always lies *parallel* on the surface to be worked on.

Handle [7]

- Push in the bolt [7-1] on the bow handle [2-2].
- Move bow handle to desired position.
- Loosen bolt and allow to engage.

Telescopic tube [2]

- Open the clamping screw [2-3].
- Move the telescopic tube [2-4] to the desired position.
- Lock the clamping screw.

8. Working with the Power Tool

1. Attach cleaning tool.
2. Connect and activate water hose.
3. Attach motor to (shoulder) belt.
4. Insert mains plug.
5. Set required speed.
6. Hold the plaster finishing machine with both hands at the gripping surfaces.
7. Switch on the device.
8. If necessary, turn the lever of the flow control valve to activate the water supply.
9. Press the tool disc **gently** against the work surface.
10. Swing the plaster finishing machine with linear or circular movements.

After finishing work

Once you have finished the grinding work, set the power tool down.



CAUTION!

Risk of damage to the device!
Do not set the power tool down with the tool disc facing downwards!

9. Maintenance and Care



WARNING!

Risk of injury, electric shock!
Always disconnect the mains plug from the socket before performing maintenance work on the machine!



CAUTION!

Risk of damage to the device!
Never immerse the disc-holding in water or spray it with water to clean it!

Repairs may be carried out by an authorized customer service center only.

Check the plug and the cable regularly and should either become damaged, in order to avoid a hazard, have them replaced by an authorized customer service center.

During the warranty period do not loosen the screws on the housing. Non-compliance will deem the guarantee obligations of the manufacturer null and void.

Checking the fluid system for leaks

Check regularly whether fluid leaks from the hoses when using the tool.

Do not use the tool if the fluid system is leaking.

Remove dust from the motor regularly

It is possible that particles deposit inside the power tool during operation. This impairs the cooling of the power tool. Conductive build-up can impair the protective insulation of the power tool and cause electrical hazards.

The power tool should be cleaned regularly, often and thoroughly through all front and rear air vents using a vacuum cleaner or by blowing in dry air. Prior to this operation, separate the power tool from the power source and wear protective glasses and dust mask.

Replacement of the flexible drive shaft [7]



CAUTION!

Risk of damage to the device!
The two boreholes [7-4] for the push button [7-3] at the drive shaft serve as length adjustment between shaft core and protective hose. The shaft core should be freely movable in length and must not get compressed!

Disassembling: On the motor side, press in the press button [7-3] in the borehole [7-4] with a tool (e.g. screwdriver) and pull out the protective hose [1-7]. Now the shaft core can be replaced.

To replace the protective hose [1-7], it must also be loosened on the side of the tool holder. To do this,

press in the press button [7-3] in the borehole [7-4] with a tool (e.g. screwdriver) and pull out the protective hose [1-7].

Mounting: In reverse order. Make sure that the shaft core is threaded into the square in each case.

Changing the splash guard

The splash guard [1-1] can be removed by stretching it slightly apart at the overlapping point and then pulling it off downwards.

Installation in reverse order. Make sure that the sheet metal angles touch the tool holder. Position the water nozzle to the opening.



ADVICE!

Check all wearing parts once a month.

10. Spare Parts and Accessories

Other accessories, in particular insertion tools, can be found in the manufacturer's catalogues. Exploded drawings and spare-part lists can be found on our homepage: www.rokamat.com.

Use only original ROKAMAT spare parts and work tools!

11. Environmental Protection

Observe national regulations on environmentally compatible disposal and on the recycling of disused machines, packaging and accessories.



For Great Britain and EU countries: Never dispose of power tools in your household waste! In accordance with WEEE relating for electrical and electronic waste and implementation of national law, used electrical tools must be collected separately and disposed of in an environmentally friendly manner at recycling centers.

Separate the motor from the rest of the machine before disposal. Make used tools unusable by removing the mains cable.



ADVICE!

Please ask your dealer about disposal options!

12. Declaration of Conformity

It is expressly declared that the grinder and polisher listed on the first page under 1) from the serial number indicated onwards complies with all relevant provisions of the directives or regulations listed in 2) and that the harmonized standards listed in 3) have been applied. The technical documentation is available from the authorized documentation agent named in 4).

13. Troubleshooting

Problem	Possible causes	Remedy
Motor runs, but the supporting plate does not rotate.	Shaft core broken.	Exchange shaft core.
	Mitre-gear of the tool holder is defective.	Replace the mitre-gear with case top.
The electronic signal display [3-1] lights up and the load speed decreases.	There is too much load on the machine.	Run the machine in idling until the electronics signal indicator switches off.
The machine does not start. The electronic signal display [3-1] flashes.	The restart protection is active. If the mains plug is inserted with the machine switched on, or if the power supply is restored following an interruption, the machine does not start up.	Switch the machine off and on again.
Motor power fluctuates.	Carbon brushes worn.	Replace carbon brushes.
	Electronic unit defective.	Replace electronic unit.
Hedgehog W not working.	PRCD not switched on	Switch on PRCD.
	Interruption to power supply.	Switch the power tool off and on again.
	Cable break.	Replace mains plug.
Hedgehog W does not run smoothly over the surface.	Incorrect speed set.	Adjust speed.
	Tool discs are not mounted correctly.	Check the correct fit of the tool discs.
Not optimal cleaning effect.	Incorrect or worn tool discs.	Select correct tool discs and check for good condition.
	Material to be processed is too dry.	Moisten material with water.
Water injection does not work (correctly).	Water supply not connected or activated.	Connect and activate the water supply.
	Nozzle blocked.	Unblock the blocked area.
	Lever valve blocked.	Unblock the blocked point.
	Lever valve defective.	Replace lever valve.

If problems other than those listed occur, please contact your ROKAMAT service workshop or your local specialist.